

TAYLOR WIMPEY HOUSE TYPE	SQ. FT (STRUCT)	NO.	TOTAL SQ. FT (STRUCT)
FLATFORD - PA33	866	14	12124
GOSFORD - PA34	866	14	12124
ARDINGHAM - PD33	967	21	20307
MIDFORD - PA44	1170	06	7020
DOWNHAM - PD48	1244	21	26124
WHITFORD - PA411	1248	06	7488
LINDALE - PT44	1290	06	7740
EYNHAM - PD410	1334	23	30682
HADDENHAM - PD411	1460	16	23360
LAIVENHAM - PD51	1646	8	13168
TOTALS		135	160137



LEGEND

* LANDSCAPING SHOWN IS INDICATIVE - PLEASE REFER TO LANDSCAPING DESIGN BY OTHERS.

REFER TO ARBORICULTURAL ASSESSMENT & CONSTRAINTS PLAN FOR WORKS TO EXISTING TREES & HEDGES & AREAS TO BE PROTECTED.

- INDICATES BRICKWORK MOVEMENT JOINT AT PARTY WALL
- (A) 1800mm CLOSE BOARDED FENCE
- (B) 800mm POST & RAIL FENCE
- (C) 1800mm BRICK SCREEN WALL
- (D) 800mm METAL ESTATE RAILINGS
- GATE

REFER TO ENCLOSURE DETAILS DRAWING FOR CORRESPONDING DETAILS

All manual gates (excluding close boarded plot pedestrian gates) are to be constructed to avoid trapping/crushing zones should the gate be opened or closed inadvertently, for instance by the wind or by another person. When open the gate should be limited to a maximum 90degree opening by means of a restricting cleat fixed to the post (hinge side). The hinge should allow for a minimum 50mm clear gap between the gate and post when open and closed to prevent entrapment

MAIN ACCESS PATHS BETWEEN PUBLIC FOOTWAY/DRIVE AND FRONT DOOR TO 900mm WIDE OVERALL

VISIBILITY TO HOUSE FRONTS TO CONSIST OF 900 x 1200mm LEVEL AREA & 900mm WIDE PATH LAID TO A MAXIMUM FALL OF 1:20. (DOOR FRAMES TO BE FITTED WITH LEVEL THRESH)

1800x1800mm PATIO OUTSIDE FRENCH DOORS

ALL PATHS ADJACENT TO EXTERNAL HOUSE WALLS TO BE 750mm OVERALL WIDTH. 150mm WIDE PEA GRAVEL MARGIN AS PART OF OVERALL WIDTH.

AREAS OF EXTERNAL WALL WITHOUT PATHS TO HAVE 300mm WIDE MOWING MARGIN COMPRISING PEA GRAVEL RETAINED BEHIND A 25mm x 150mm SW CROSSOTED TIMBER EDGING.

● BIN STORAGE AREA WITHIN REAR GARDENS CONSISTING OF 1.2x2.1M PAVED AREA.

MATERIALS AND COLOUR SCHEDULE

CODE	MAIN BRICK
1	WIENERBERGER DORTON MANOR STOCK
2	WIENERBERGER GAINSBROUGH MULTI
R	PAREX MONOCOUCHE RENDER - IVORY
CODE	ROOF TILE
A	RUSSELL CEMEX GRAMPIAN SLATE GRAY
B	RUSSELL CEMEX PENINE RUSTIC PEAT
ARTSTONE	AMBER PRECAST BATHSTONE

GENERAL NOTES

ALL JOINERY TO BE WHITE
 ALL RAINWATER GOODS TO BE BLACK SQUARE PVCU
 FRONT ENTRANCE DOORS TO BE BLACK
 GARAGE DOOR COLOURS TO BE BLACK

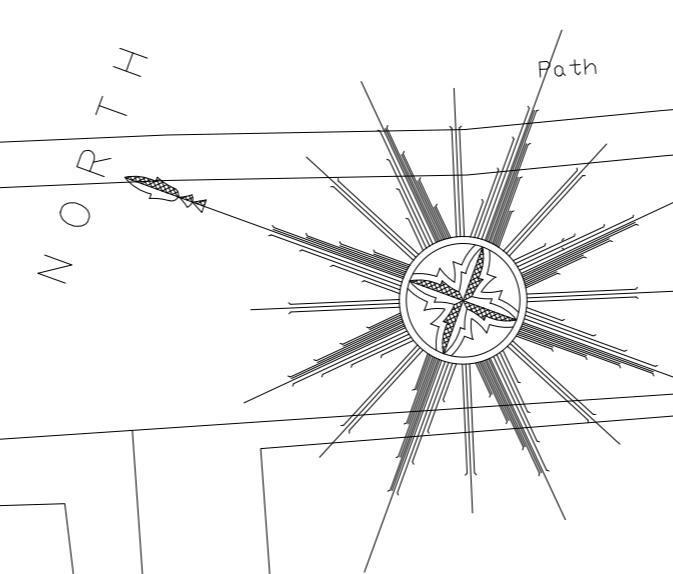

D 22.09.15 Amended to further highway comments NB
 C 07.09.15 Amended to further highway comments NB
 B 25.08.15 Drawing scale corrected to 1:500 NB
 A 22.07.15 Layout amended to highways comments incl extra VPs. NB

REVISION DATE DESCRIPTION BY
 JOB Monkton Phase 2
 TAYLOR WIMPEY
 SITE LAYOUT
 WITH MATERIALS SCHEDULE
 SCALE 1:500 DRAWN NB (IND)
 @ AO DATE Oct.14 DATE
 Taylor Wimpey North East
 North House, Westington Way
 Sunderland SRS 98L
 Telephone 0191 5165400
 Fax 0191 5165401
Taylor Wimpey

Monkton Fell Monkton Fell